

Introduction



Originally, the EL1883 is designed to use in the NTSC, PAL and SECAM (Bi-level sync) applications. But with some external circuitries, it can also be used to separate most of the HDTV (Tri-level sync) signals automatically.

Circuit Description

Normally, the EL1883 uses a resistor R_{SET} to control the internal timing. It is a current source and the current is set by

the value of R_{SET} . The resistor R_{SET} needs to be changed for different line rate. With the following frequency to current conversion circuit, the EL1883 can detect most of the HDTV video signals automatically without changing R_{SET} . The composite sync is passed through an emitter follower Q1. The differentiator C2 and R5 generates a positive going voltage spike at the rise edge of the composite sync pulse. The voltage spike turns on Q2 and discharge C4. R1 is used to reduce the miller capacitor coupling effect on C4. R2, R3, C3 and C4 form a charge tank.

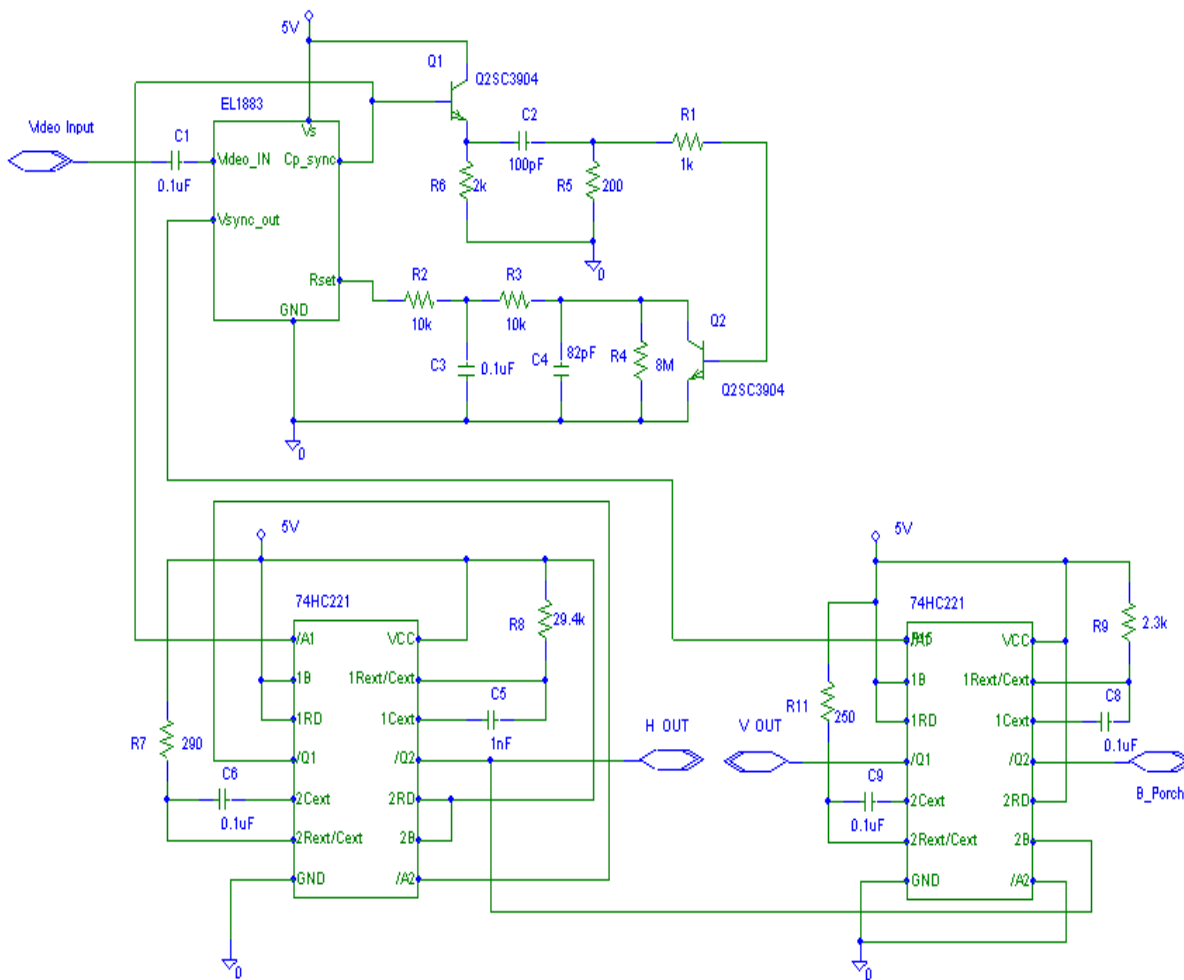

As the line rate increases, the discharge rate also increases. The average current sources out from R_{SET} pin increases. R4 is a start up resistor.

Using the 74HC221, a dual non-retriggerable monostable multivibrator, can generate a true horizontal line, back porch pulse and vertical line.

Horizontal Sync and Back porch generator

The composite sync is input to /A1 pin of the 74HC221. R8 and C5 set the pulse width at about 21 μ s to eliminate the half line pulse for the composite sync. The output of /Q1 is connected to /A2. R7 and C6 set the pulse width of the output horizontal sync to about 4 μ s. The Back porch pulse can be used for DC restored application and generated from

the Horizontal Sync output. R11 and C9 set the pulse width to be about 5 μ s for the Back Porch output.

Vertical Sync generator

The Vertical Sync from EL1883 is connected to /A1 of the 74HC221. R9 and C8 set the output pulse width to about 180 μ s to eliminate the double pulse from the EL1883's Vertical Sync. The vertical pulse should have only the leading negative going edge used for timing as the trailing edge is a timer pulse and not hard synced to the video.

With the above circuit, it works for the following HDTV signals: 720P50~60, 1035I29~30, 1080I23~30 and 1080P23~30. It doesn't work for 1080P50~60.

Performance Curves

CH1---Composite Video input
 CH2---Composite Video output
 CH3---Horizontal Sync output
 CH4---Vertical Sync output

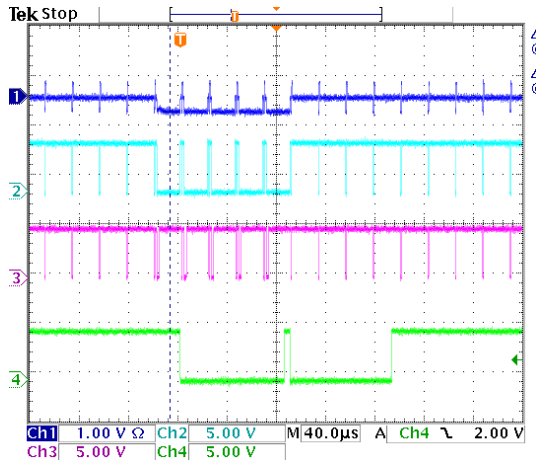

FIGURE 1. 720P50---OUTPUT FROM EL1883

CH1---Composite Video input
 CH2---Composite Video output
 CH3---Horizontal Sync output
 CH4---Vertical Sync output

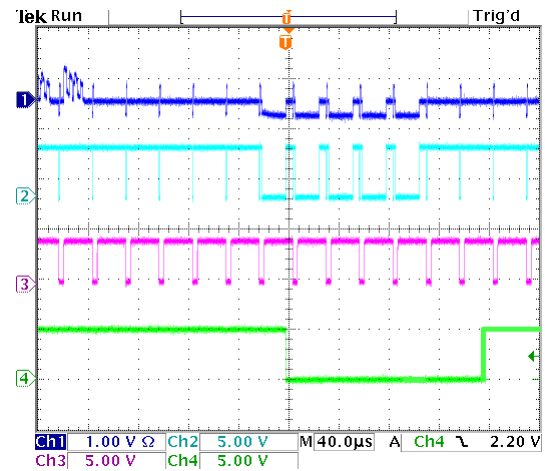

FIGURE 2. 720P50---OUTPUT AFTER THE 74HC221

Performance Curves (Continued)

CH1---Composite Video input
 CH2---Composite Video output
 CH3---Horizontal Sync output
 CH4---Vertical Sync output

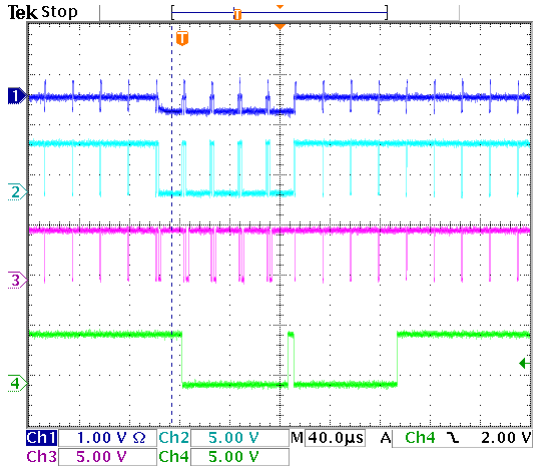

FIGURE 3. 720P59 AND 720P60---OUTPUT FROM EL1883

CH1---Composite Video input
 CH2---Composite Video output
 CH3---Horizontal Sync output
 CH4---Vertical Sync output

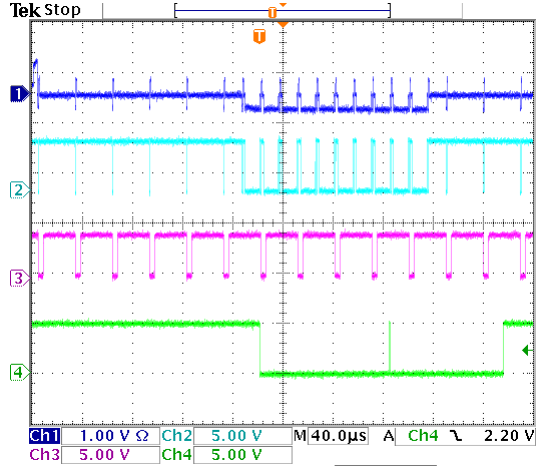

FIGURE 4. 1035I29---OUTPUT FROM EL1883

CH1---Composite Video input
 CH2---Composite Video output
 CH3---Horizontal Sync output
 CH4---Vertical Sync output

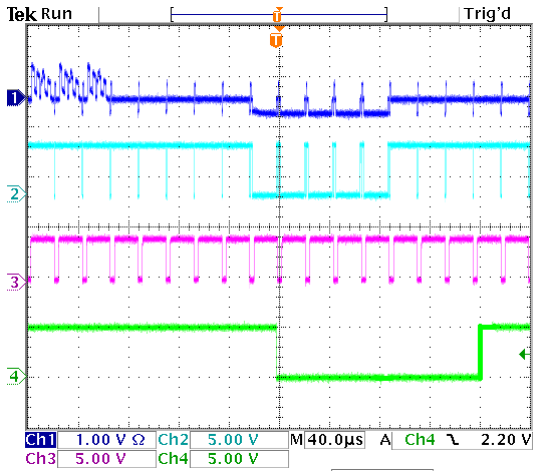

FIGURE 5. 720P59 AND 720P60---OUTPUT AFTER THE 74HC221

CH1---Composite Video input
 CH2---Composite Video output
 CH3---Horizontal Sync output
 CH4---Vertical Sync output

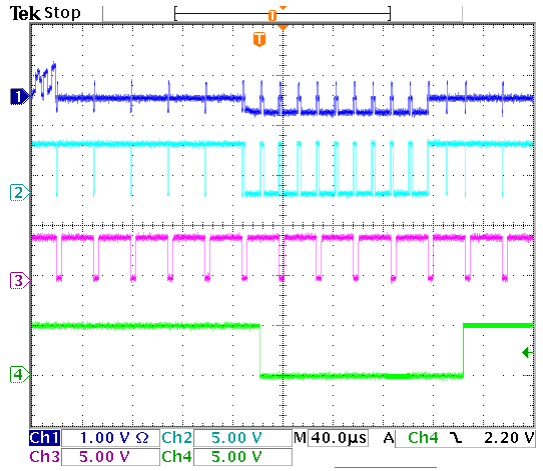

FIGURE 6. 1035I29---OUTPUT AFTER THE 74HC221

Performance Curves (Continued)

CH1---Composite Video input
 CH2---Composite Video output
 CH3---Horizontal Sync output
 CH4---Vertical Sync output

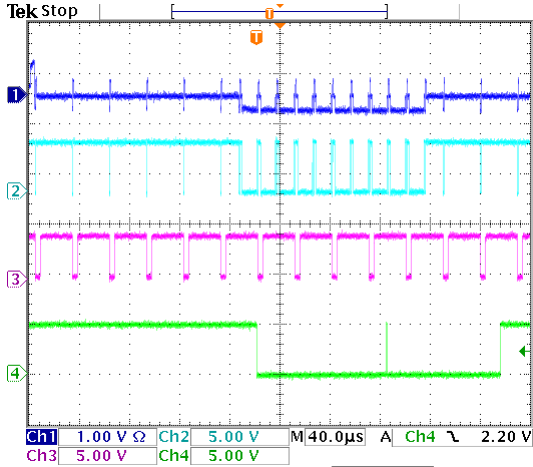

FIGURE 7. 1035I30---OUTPUT FROM EL1883

CH1---Composite Video input
 CH2---Composite Video output
 CH3---Horizontal Sync output
 CH4---Vertical Sync output

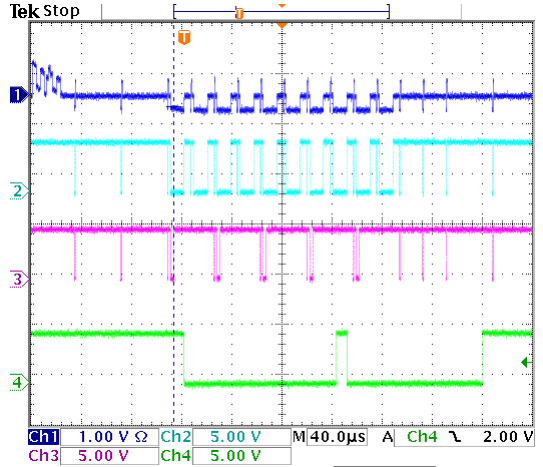

FIGURE 8. 1080I23 AND 1080I24---OUTPUT FROM EL1883

CH1---Composite Video input
 CH2---Composite Video output
 CH3---Horizontal Sync output
 CH4---Vertical Sync output

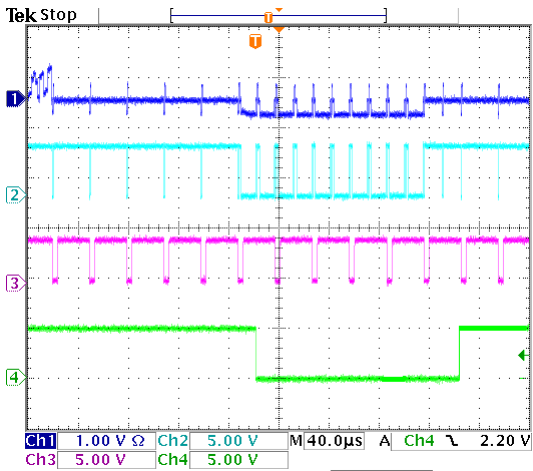

FIGURE 9. 1035I30---OUTPUT AFTER THE 74HC221

CH1---Composite Video input
 CH2---Composite Video output
 CH3---Horizontal Sync output
 CH4---Vertical Sync output

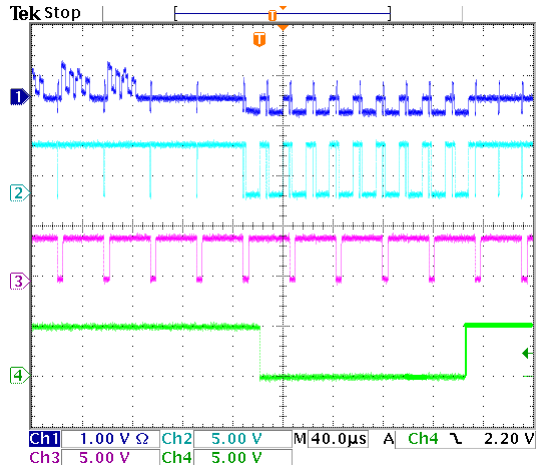

FIGURE 10. 1080I23 AND 1080I24---OUTPUT AFTER THE 74HC221

Performance Curves (Continued)

CH1---Composite Video input
 CH2---Composite Video output
 CH3---Horizontal Sync output
 CH4---Vertical Sync output

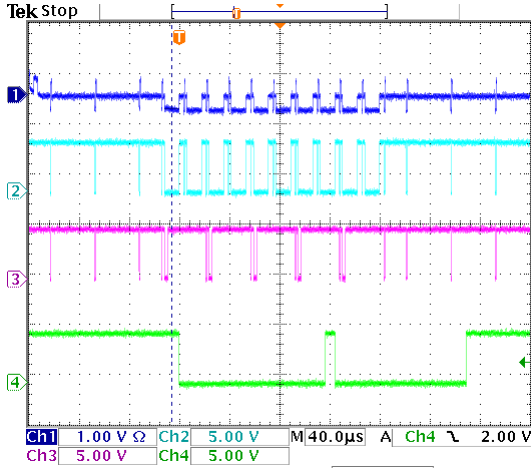

FIGURE 11. 1080I25 H28, V50---OUTPUT FROM EL1883

CH1---Composite Video input
 CH2---Composite Video output
 CH3---Horizontal Sync output
 CH4---Vertical Sync output

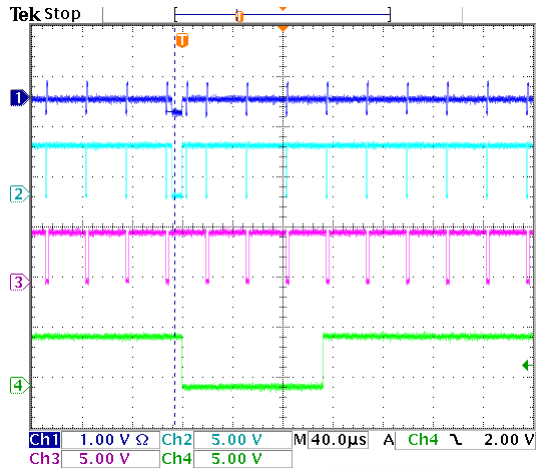

FIGURE 12. 1080I25 H31, V50---OUTPUT FROM EL1883

CH1---Composite Video input
 CH2---Composite Video output
 CH3---Horizontal Sync output
 CH4---Vertical Sync output

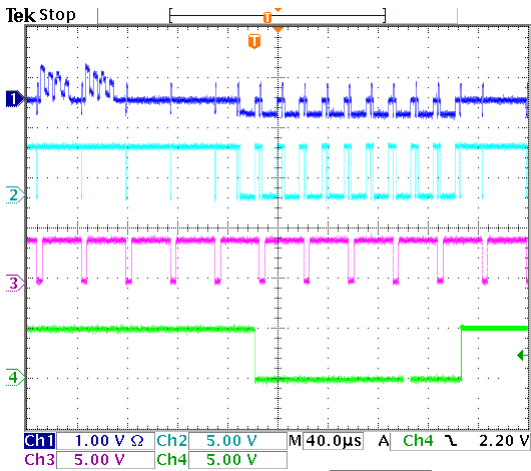

FIGURE 13. 1080I25 H28, V50---OUTPUT FROM 74HC221

CH1---Composite Video input
 CH2---Composite Video output
 CH3---Horizontal Sync output
 CH4---Vertical Sync output

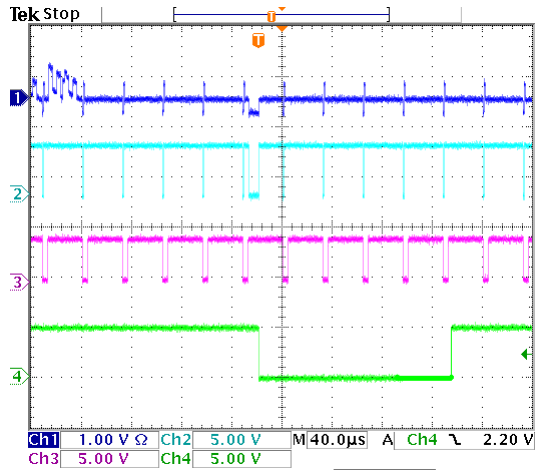

FIGURE 14. 1080I25 H31, V50---OUTPUT FROM 74HC221

Performance Curves (Continued)

CH1---Composite Video input
 CH2---Composite Video output
 CH3---Horizontal Sync output
 CH4---Vertical Sync output

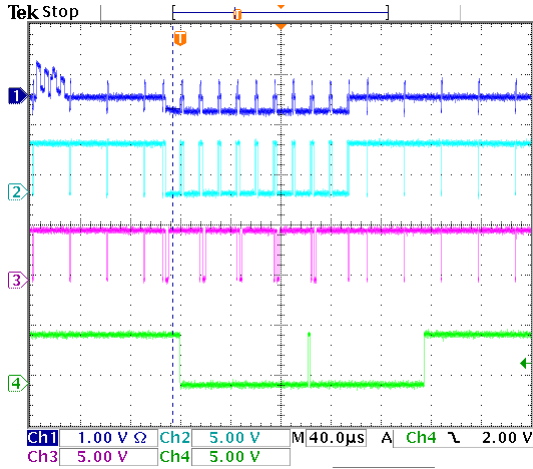

FIGURE 15. 1080I29 AND 1080I30---OUTPUT FROM EL1883

CH1---Composite Video input
 CH2---Composite Video output
 CH3---Horizontal Sync output
 CH4---Vertical Sync output

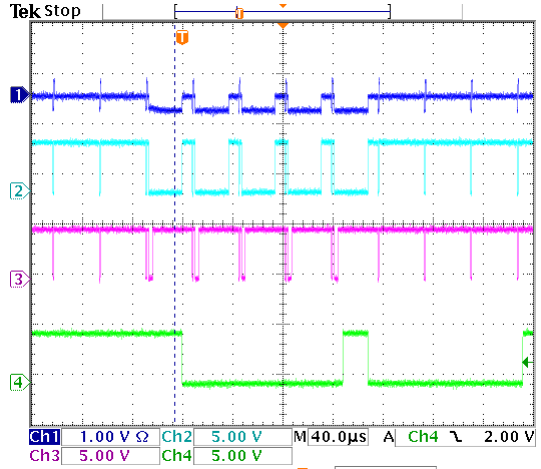

FIGURE 16. 1080P23 AND 1080P24---OUTPUT FROM EL1883

CH1---Composite Video input
 CH2---Composite Video output
 CH3---Horizontal Sync output
 CH4---Vertical Sync output

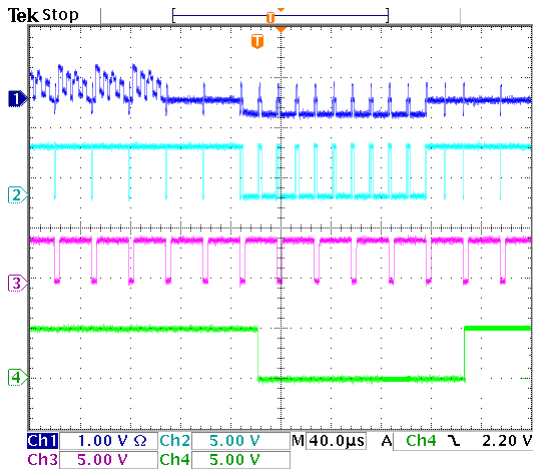

FIGURE 17. 1080I29 AND 1080I30---OUTPUT FROM 74HC221

CH1---Composite Video input
 CH2---Composite Video output
 CH3---Horizontal Sync output
 CH4---Vertical Sync output

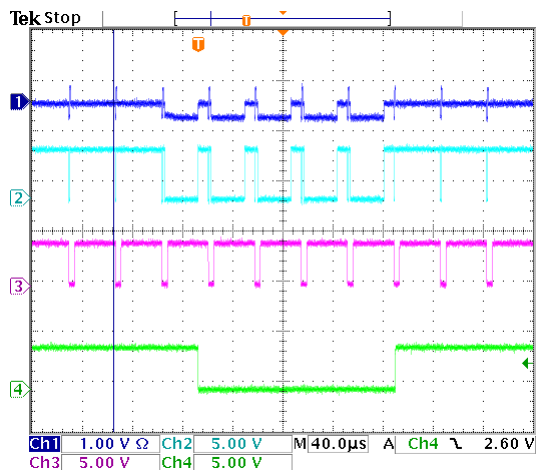

FIGURE 18. 1080P23 AND 1080P24---OUTPUT FROM 74HC221

Performance Curves (Continued)

CH1---Composite Video input
 CH2---Composite Video output
 CH3---Horizontal Sync output
 CH4---Vertical Sync output

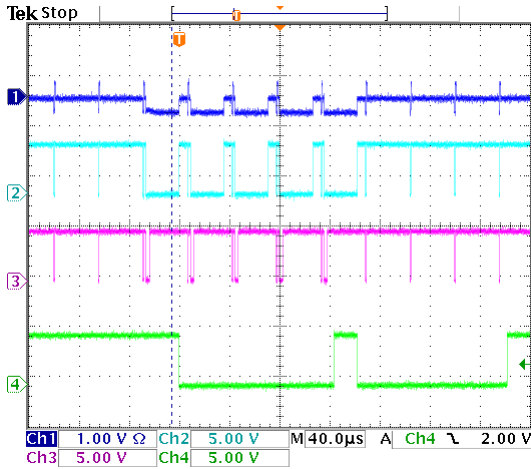

FIGURE 19. 1080P25---OUTPUT FROM EL1883

CH1---Composite Video input
 CH2---Composite Video output
 CH3---Horizontal Sync output
 CH4---Vertical Sync output

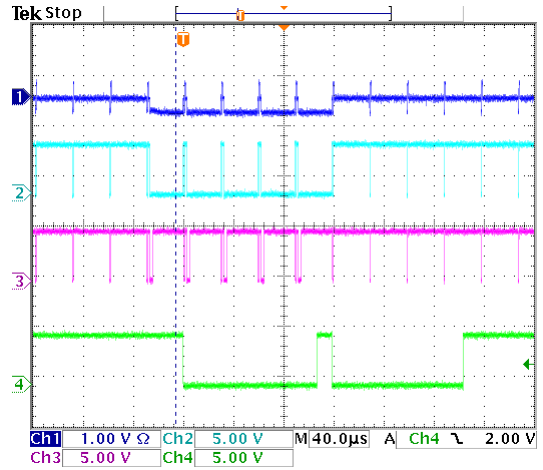

FIGURE 20. 1080P29 AND 1080P30---OUTPUT FROM EL1883

CH1---Composite Video input
 CH2---Composite Video output
 CH3---Horizontal Sync output
 CH4---Vertical Sync output

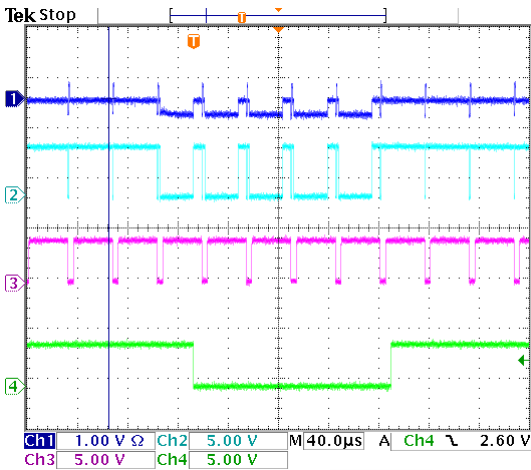

FIGURE 21. 1080P25 ---OUTPUT FROM 74HC221

CH1---Composite Video input
 CH2---Composite Video output
 CH3---Horizontal Sync output
 CH4---Vertical Sync output

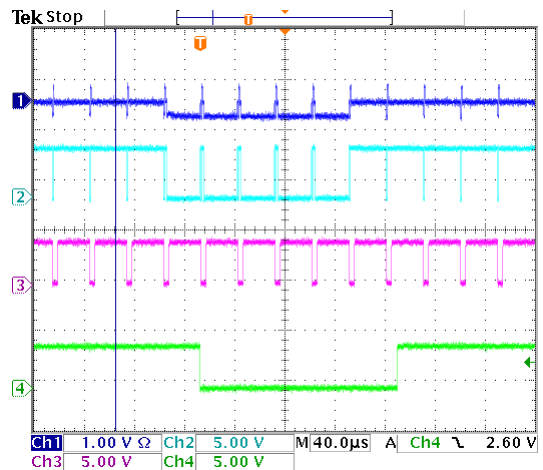

FIGURE 22. 1080P29 AND 1080P30---OUTPUT FROM 74HC221

All Intersil U.S. products are manufactured, assembled and tested utilizing ISO9000 quality systems.
 Intersil Corporation's quality certifications can be viewed at www.intersil.com/design/quality

Intersil products are sold by description only. Intersil Corporation reserves the right to make changes in circuit design, software and/or specifications at any time without notice. Accordingly, the reader is cautioned to verify that data sheets are current before placing orders. Information furnished by Intersil is believed to be accurate and reliable. However, no responsibility is assumed by Intersil or its subsidiaries for its use; nor for any infringements of patents or other rights of third parties which may result from its use. No license is granted by implication or otherwise under any patent or patent rights of Intersil or its subsidiaries.

For information regarding Intersil Corporation and its products, see www.intersil.com